

Serie B2.1

va tech²⁰⁰⁰

Flanged ductile iron ball valve

Shut-off valves

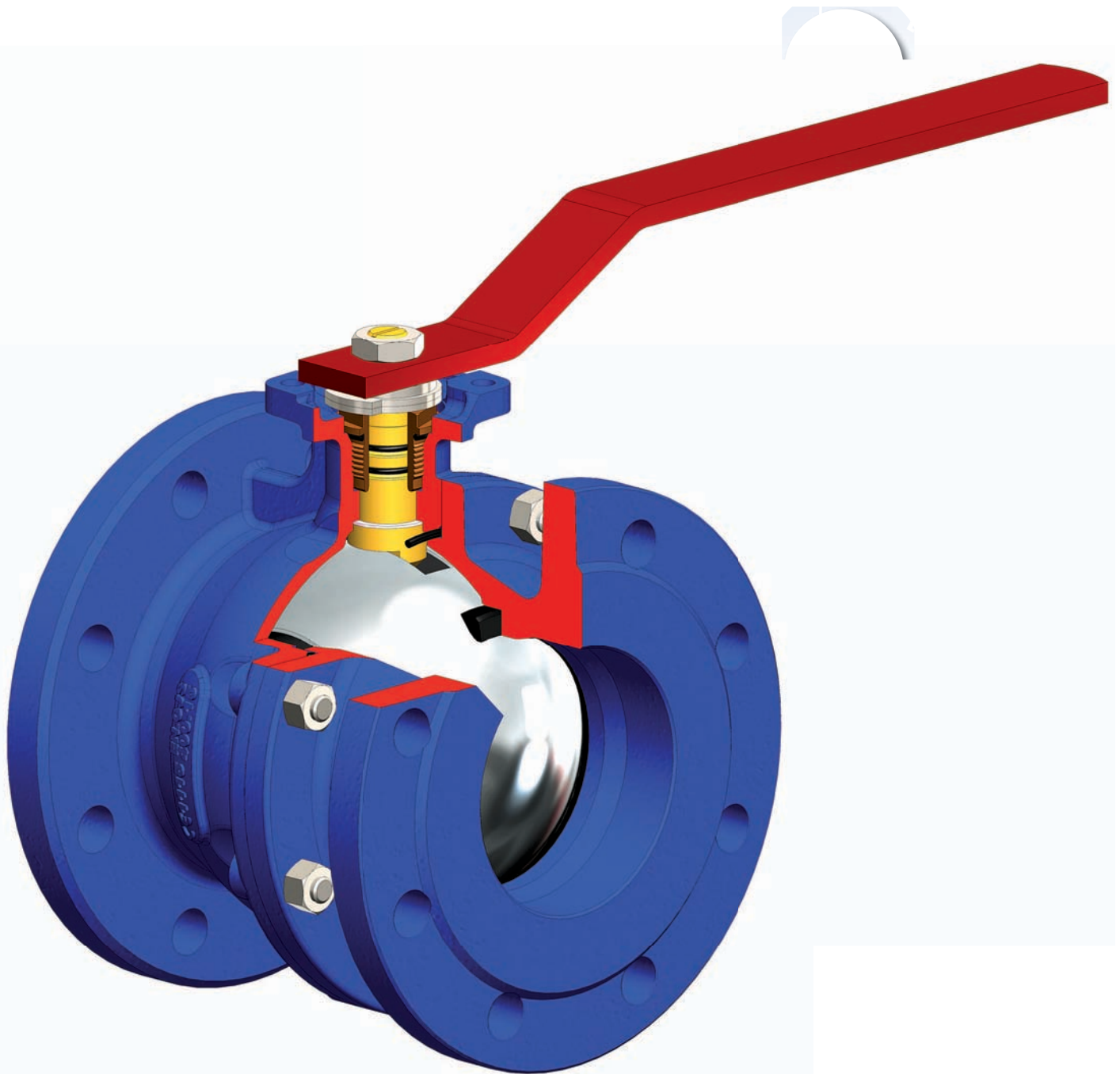

Application fields



WATER



CONDITIONING



GAS



HEATING



INDUSTRY



FIRE FIGHTING

Series B2.1 valves are shut-off ball valves split-body type in ductile iron and floating ball, manufactured according to the severe product standards and the quality management relative to ISO 9001.

Suitable for heating and conditioning (HVAC), district heating, distribution and treatment of water, industrial application, agricultural application, for compressed air processing, for oils and hydrocarbon.

(Please ensure the choice of the corresponding item)

YES: for installation in line and end of line, for services with frequent acting, the integrated ISO 5211 support allows the installation of a wide range of actuators.

The B2.1 range of ball valves are full and straight bore reducing turbulences and minimizing head loss.

NO: for steam, for choking and flow regulation.

1. Inside and outside epoxy coating, high temperature resistant. Environmentally friendly, water-based paint.
2. Integrated flange, in accordance with ISO 5211.
3. Removing and repositioning of the plate at 90° allows locking of the valve in ON-OFF position.
4. The dynamic seal of the stem is guaranteed by a double O-ring, even in severe working conditions.
5. Blow-out proof stem.
6. Seat of ball in reinforced PTFE, as temperature changes, the torque remains constant.
7. Ball with full and straight bore, in chromed brass or stainless steel.

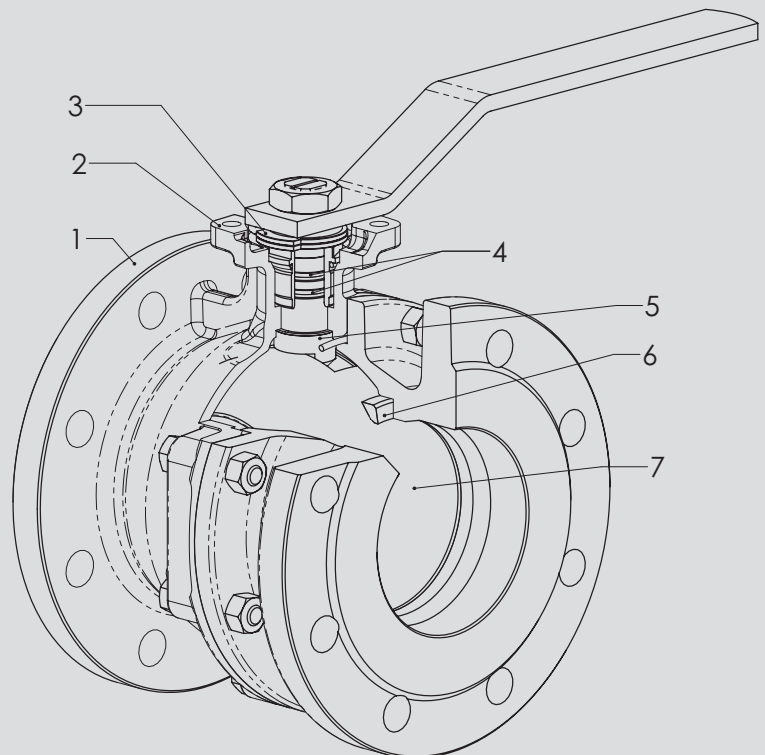

Accessories

- ➔ Stem extension for thermal insulation
- ➔ Square cap for water main system connection
- ➔ Stem extension
- ➔ Kit ISO 5211 flange
- ➔ Kit lockable operation lever
- ➔ Kit limit switches for ON/OFF position indicator

Refer to specifications on page 32

Actuators

- ➔ Double acting and single acting pneumatic actuators
On request: limit switches, position indicator
- ➔ Electric actuators
- ➔ Gear box

Special items

- ➔ Through-drilled ball for legionella thermal preventive treatment
- ➔ Drainage plug

CE In conformity with directive 97/23/CE PED

DVGW Conformity to EN 13774 norms,
DVGW certification for gas

Construction and testing norms (correspondences):

Face-to-face: EN558/1 (ISO 5752)
Flanges: EN1092, ANSI B16.5 #150
Design: EN 1983, EN13445, ISO 5211
Marking: EN19
Testing: 100% testing in accordance with EN 12266 cat. A
(ISO 5208 cat. A)

Flanged ductile iron ball valve

B2.1 - DN 15- 150

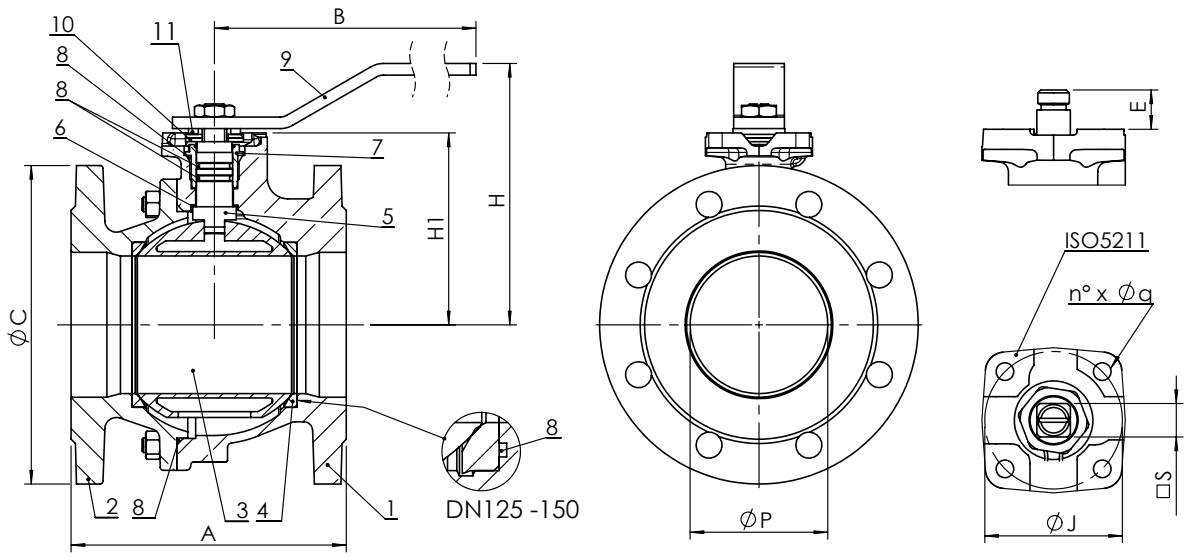

B2.0/B2.1 - DN 200

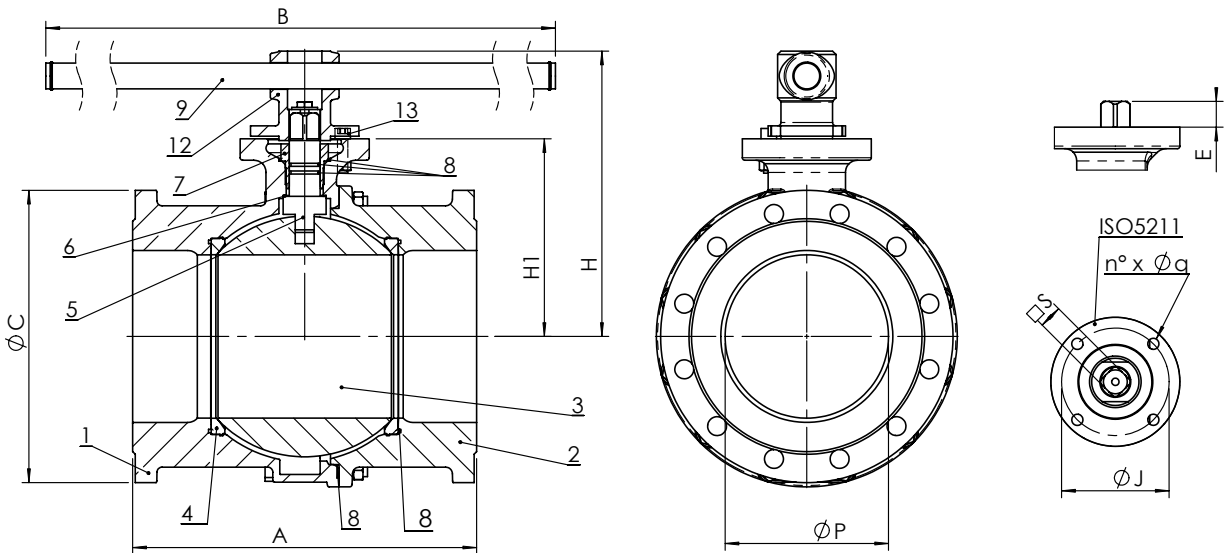

B2.0/B2.1 - DN 250

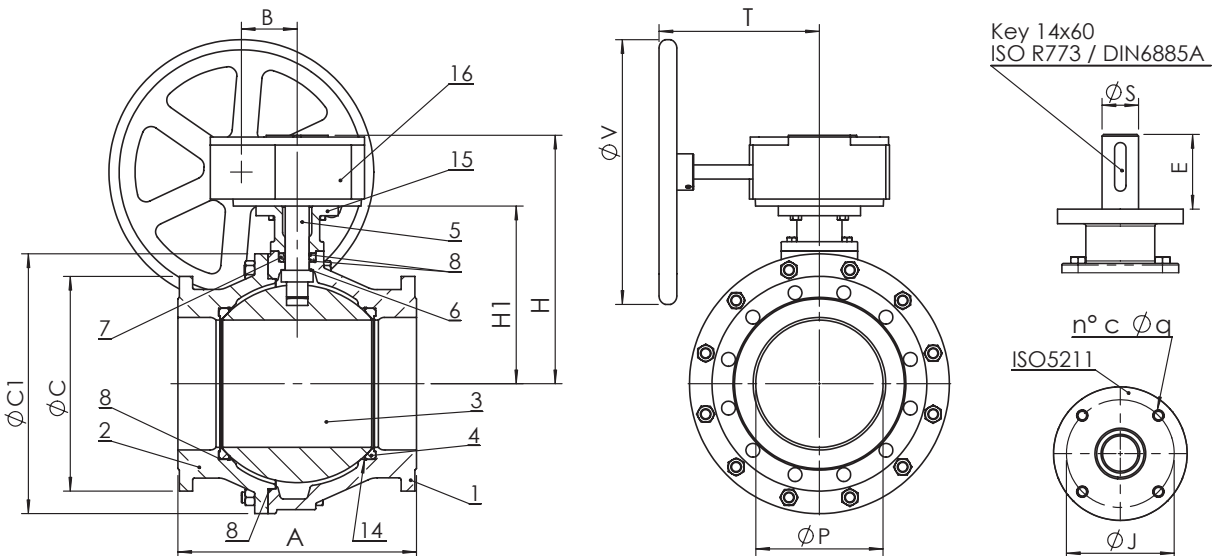

Materials

	Component	Material
1	Body	EN GJS 400-15 / EN GJL250*, epoxy coated
2	Flange	EN GJS 400-15 / EN GJL250*, epoxy coated
3	Ball	Brass CuZn40Pb2 chrome plated / AISI 304 / AISI 316 / EN GJL250**
4	Ball seat	Reinforced PTFE
5	Stem	Brass CuZn40Pb2 / AISI 304 / AISI 316
6	Sliding washer	PTFE
7	Ring	Brass CuZn40Pb2 / AISI 304 / AISI 316
8	O-Ring	NBR /FKM (Viton®)
9	Lever	Carbon steel, epoxy coated
10	Stop plate	Galvanized carbon steel
11	Spring washer	Galvanized carbon steel
12	Lever hub	EN GJS 400-15
13	Lever stop	Galvanized carbon steel
14	Anti-blow-out ring	AISI 302
15	Mounting pad for gear box	EN GJS 400-15 / EN GJL 250
16	Gear box	-
17	Bolts	Galvanized carbon steel

*: only DN 200-250

** : DN 250 with ball in EN GJL 250 - CODE: 02.040

Dimensions (mm)

DN		15	20	25	32	40	50	65	80	100	125	150	200	250***
P		15	20	25	32	40	50	63	76	95	120	145	190	240
A (B2.1)	EN 558/1 - 14 (ex DIN 3202 F4)	115	120	125	130	140	150	170	180	190	200	210	-	-
A (B2.0)	EN 558/1 - 14 (ex DIN 3202 F5)	-	-	-	-	-	-	-	-	-	-	-	400	450
A (F2.1)	EN 558/1 - 29 (ex NF 29-323)	-	-	-	-	136	142	154	160	172	186	200	-	-
H		84	84	96	101	125	135	143	165	180	225	243	320	448
H1		50,5	52	59	64	78,5	87	95	118	132,5	165	182,5	230	335
B		160	160	170	170	230	230	230	280	360	450	560	1000	101
C	EN1092/2 PN 16	95	105	115	140	150	165	185	200	220	250	285	340	405
C1		-	-	-	-	-	-	-	-	-	-	-	-	490
V		-	-	-	-	-	-	-	-	-	-	-	-	500
T		-	-	-	-	-	-	-	-	-	-	-	-	284
ISO 5211		F04	F04	F04	F04	F05	F05	F05	F07	F07	F10	F10	F12	12
J		42	42	42	42	50	50	50	70	70	102	102	125	125
n° x Ø q		4 x 6	4 x 6	4 x 6	4 x 6	4 x 7	4 x 7	4 x 7	4 x 9	4 x 9	4 x 11	4 x 11	4 x 13	4 x 13
E		11,5	11,5	14,5	14,5	17,5	17,5	17,5	20	20	24,5	24,5	27	92
S		□ 9	□ 9	□ 11	□ 11	□ 14	□ 14	□ 14	□ 17	□ 17	□ 22	□ 22	□ 27	□ 45

Weight (kg)

B2.100	2,6	3,3	4,2	5,8	7,5	9	10,5	15,5	18,5	28	38,5	93	180
B2.111 - B2.122	2,6	3,3	4,2	5,8	7,8	9,7	12,2	16,7	22,2	35,8	46,6	117	180

Operating torque (Nm)

Nm	15	15	18	18	18	20	40	70	100	180	250	600	2000
----	----	----	----	----	----	----	----	----	-----	-----	-----	-----	------

N.B.: In order to choose the right actuator, we recommend multiplying the operating torque figure by a safety coefficient, $K=1.5$

***: The diameter DN 250 is supplied with gear box as standard

Drilling

DN		15	20	25	32	40	50	65	80	100	125	150	200	250
Dimensions of flanges according to PN 16EN1092/2	Drilling PN 16 EN1092/2	std	std	std	std	std	std	std	std	std	std	std	std	std
	Drilling PN 10 EN1092/2	=	=	=	=	=	=	=	=	=	=	=	opt	opt
	Drilling PN 6 EN1092/2	opt	opt	opt	opt	opt	opt	opt	opt	opt	opt	opt	opt	opt
	Drilling ANSI B16.5 #150	opt	opt	opt	opt	opt	opt	opt	opt	opt	opt*	opt	opt	opt

std: standard / opt: option on request / =: same as PN16

Flanged ductile iron ball valve

Maximum pressure

Fluids *	Mounting	
	BETWEEN FLANGES	END OF LINE
Hazardous gases	16 bar DN15-200 10 bar DN250	10 bar DN15-100 NO DN125-250
Hazardous liquids	16 bar DN15-200 10 bar DN250	10 bar
All remaining fluids	16 bar DN15-200 10 bar DN250	10 bar

*: Hazardous gas, liquids (explosive, inflammable, toxic) in accordance with 97/23/CE PED and 67/548/EEC

Temperature

Temperature	min °C	Max°C	
		continuous	peak
NBR	-10	100	110
FKM (Viton®)	-10	150	170

NB: the maximum working pressure decreases while temperature increases, please refer to "pressure/temperature" chart

Pressure/temperature chart

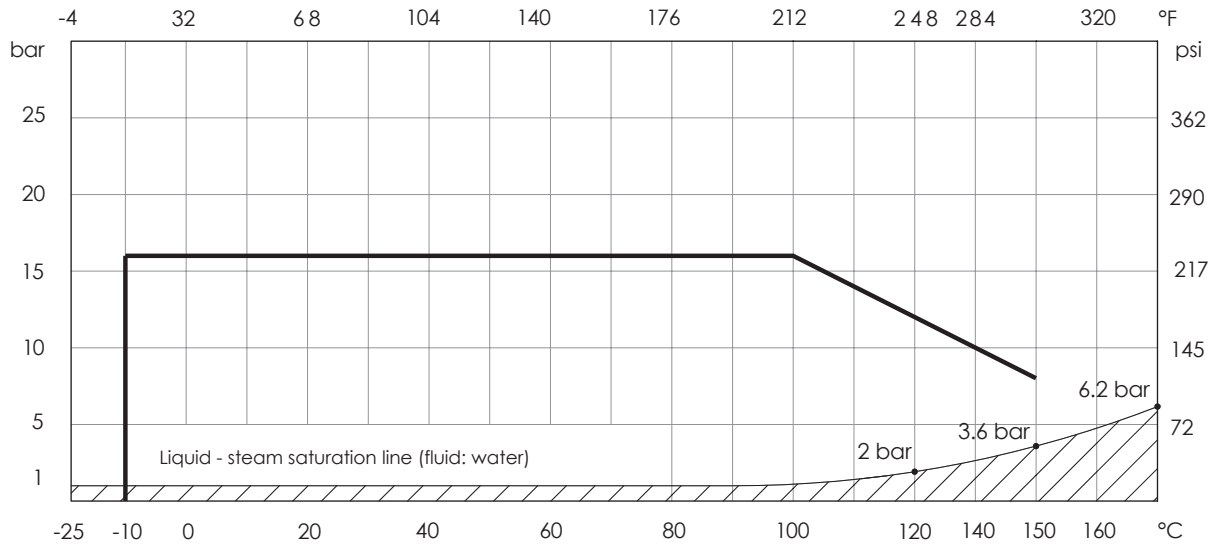

RANGE NOT SUITABLE FOR STEAM. DO NOT use when temperature and pressure are below the liquid-steam saturation line (hatched area)

Head loss Fluid: water (1m H₂O = 0,098bar)

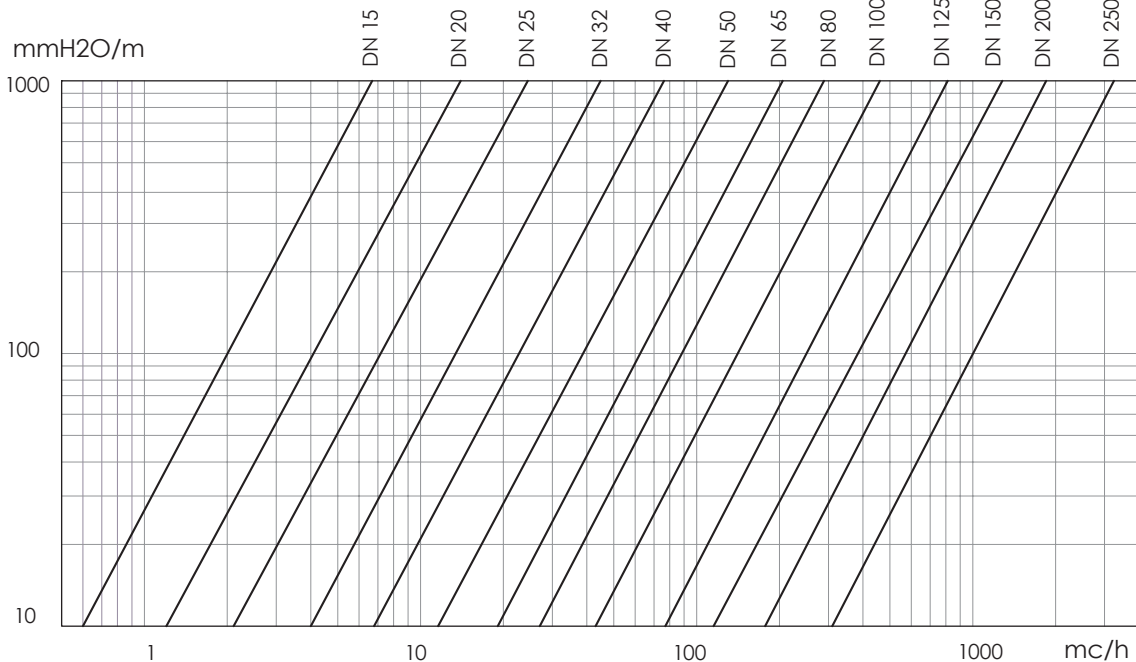

Kv - DN chart

DN	15	20	25	32	40	50	65	80	100	125	150	200	250
Kv	22,3	47,7	83,5	150,4	255	435	672	947	1508	2633	4261	5957	10510

Versions

O-Ring: NBR



B2.100

Body: EN GJS 400-15
Ball: Brass CuZn40Pb2
Stem: Brass CuZn40Pb2
O-ring: NBR
Temp: -10 +100°C

B2.110

Body: EN GJS 400-15
Ball: AISI 304
Stem: Brass CuZn40Pb2
O-ring: NBR
Temp: -10 +100°C

B2.111

Body: EN GJS 400-15
Ball: AISI 304
Stem: AISI 304
O-ring: NBR
Temp: -10 +100°C

B2.121

Body: EN GJS 400-15
Ball: AISI 316
Stem: AISI 304
O-ring: NBR
Temp: -10 +100°C

Available with item code **B2.0** → for dimensions DN 200 – 250

B2.000

Body: EN GJL 250

B2.010

Body: EN GJL 250

B2.011

Body: EN GJL 250

B2.021

Body: EN GJL 250

Available with item code **F2** → Face to face in accordance with EN 558/1-29 (ex NF 29-323)

F2.100

See: B2.100

F2.110

See: B2.110

F2.111

See: B2.111

F2.121

See: B2.121

Coating: **RAL 5002** colour

For Gas



B2.100 Gas

Body: EN GJS 400-15
Ball: Brass CuZn40Pb2
Stem: Brass CuZn40Pb2
O-ring: NBR
Temp: -10 +70°C

B2.110 Gas

Body: EN GJS 400-15
Ball: AISI 304
Stem: Brass CuZn40Pb2
O-ring: NBR
Temp: -10 +70°C

B2.111 Gas

Body: EN GJS 400-15
Ball: AISI 304
Stem: AISI 304
O-ring: NBR
Temp: -10 +70°C

B2.121 Gas

Body: EN GJS 400-15
Ball: AISI 316
Stem: AISI 304
O-ring: NBR
Temp: -10 +70°C

Coating: **RAL 5002** colour

O-Ring: FKM



B2.100 FKM

Body: EN GJS 400-15
Ball: Brass CuZn40Pb2
Stem: Brass CuZn40Pb2
O-ring: FKM
Temp: -10 +150°C

B2.110 FKM

Body: EN GJS 400-15
Ball: AISI 304
Stem: Brass CuZn40Pb2
O-ring: FKM
Temp: -10 +150°C

B2.111 FKM

Body: EN GJS 400-15
Ball: AISI 304
Stem: AISI 304
O-ring: FKM
Temp: -10 +150°C

B2.121 FKM

Body: EN GJS 400-15
Ball: AISI 316
Stem: AISI 304
O-ring: FKM
Temp: -10 +150°C

Coating: **RAL 5002** colour

*** Most suitable for district heating → for water up to 150 °C**

Special versions on request

Accessories for series B1 - B2.1 - B2.3/7

Stem extension for thermal insulation

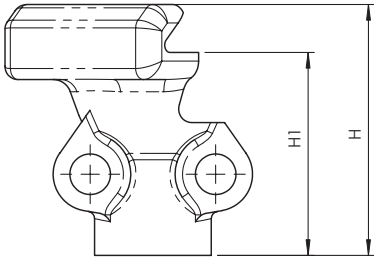

DN	40-50-65	80-100-125-150
H	68	68
H1	55	55

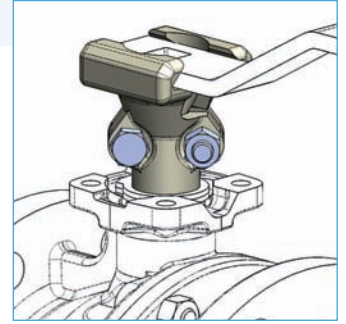

Square cap for water main system connection

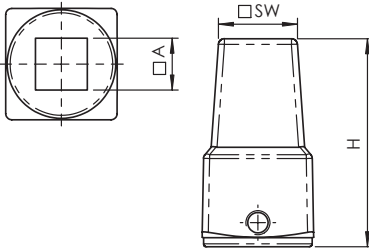

DN	40-50-65	80-100	125-150
SW	26	26	26
A	14	17	22
H	69	69	71

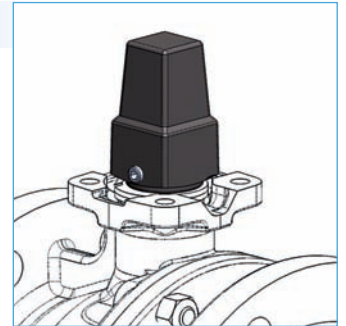

Stem extension for water main system connection

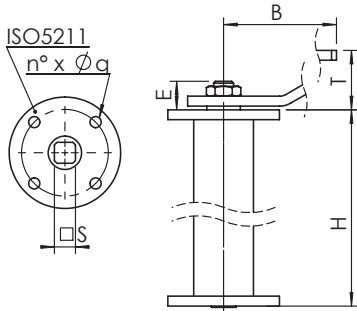

DN	40	50	65	80	100	125	150
H	250-500-800-1000						
T	48	48	48	48	48	59	59
B	230	230	230	280	360	450	560
ISO 5211	F05	F05	F05	F07	F07	F10	F10
J	50	50	50	70	70	102	102
n° x Øq	4 x 7	4 x 7	4 x 7	4 x 9	4 x 9	4 x 11	4 x 11
E	22	22	22	23	23	27	27
S	14	14	14	17	17	22	22

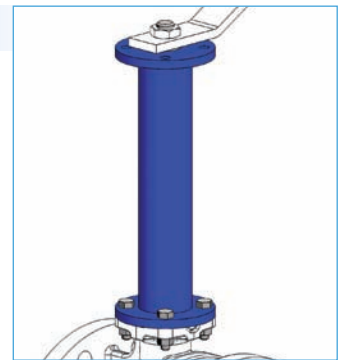

Kit ISO 5211 flange

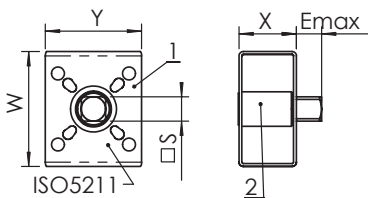

- 1) Bracket
- 2) Joint

DN	15-20	25-32	40-50-65	80	100	125	150
ISO 5211*	F04-05-07	F04-05-07	F05-07	F10-12	F10-12	F10-12	F10-12-14
S x E	14 x 14	17 x 17	17 x 17	22 x 22	27 X 27	27 X 27	36 X 36
S1 x E1**	11 x 11	11 x 11	-	-	-	-	-
Drilling valve side	F03-04	F03-04	F05-07	F07-10	F07-10	F07-10	F10-12-14
X	40	40	50	60	60	60	80
Y	70	70	70	120	120	120	140
W	80	80	100	120	120	120	160

* Drilling actuator side ** for B1 series Other top squares S on request

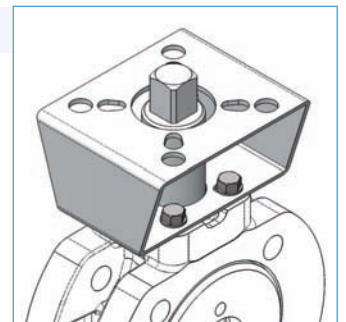

Kit lockable operation lever

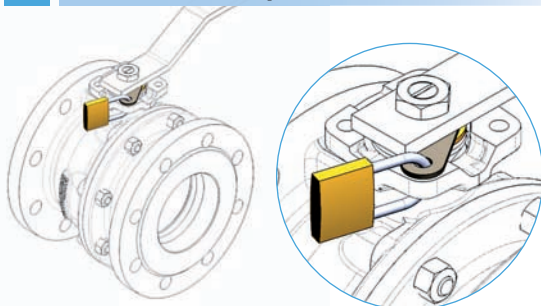

Kit limit switches for ON/OFF position indicator

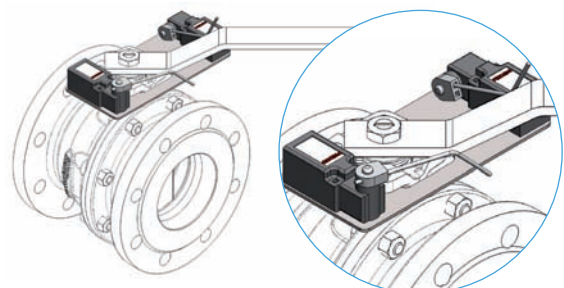

Instructions and Recommendations for series B1 - B2.1 - B2.3/7

The information provided here is delivered with each product, and contains "Instructions for use and maintenance"; it is also available on our website: www.brandoni.it (download section)

STORING

- Keep in a dry and closed place.
- While stored, the valve must be fully open to avoid damage to the seats.

MAINTENANCE

- It is recommended that the rubber O-rings be replaced at least every 24 months, and the PTFE seats, at least every 48 months. The period of replacement depends on the use of the valve.
- Clean the surface of the valve periodically, in order to prevent the accumulation of dust.

RECOMMENDATIONS

Before carrying out maintenance, or dismantling the valve, be sure that the pipes, valves and liquids have cooled down, that the pressure has decreased and that the lines and pipes have been drained in case of toxic, corrosive, inflammable or caustic liquids. Temperatures above 50°C and below 0°C might cause damage to people.

INSTALLATION

- Handle with care. The valve must be installed in either the ON or OFF position.
 - Place the valve between the flanges of the pipe and install the seal between the pipe and valve flanges. Check the correct position of the seals.
 - The distance between the counter flanges should be equal to the valve's face to face distance. Do not use bolts of the counter flanges to bring the piping close to the valve. The bolts should be cross tightened.
 - Do not weld the flanges to the piping after installing the valve.
 - Water hammers might cause damage and ruptures. Inclinations, torsions and misalignments of the piping may subject the installed valve to excessive stresses. It is recommended that elastic joints be used in order to reduce such effects as much as possible.
 - While heating from room temperature to the high operating temperature, the liquid located between the body and ball (valve open), or located in the bore of the ball (valve closed) tends to expand and may damage the ball and the seats; it is recommended that the valve be opened and closed at intermediate temperatures during the heating process (for example, at 40°C /60°C/...).
- Special valves with drain plugs are available for this application.
- At sub-zero temperatures, the liquid between the body and ball may freeze, causing irreparable damage. If the valve is exposed to such conditions, insulation of the valve is recommended.
 - It is recommended that the valve be operated periodically, to prevent the build-up of materials on the ball and the seats, particularly in the presence of limestone.

SEALING PROCEDURE

