

**Serie 04.1**

**va tech**<sup>2000</sup>

Three-way flanged cast iron ball valve

Shut-off valves

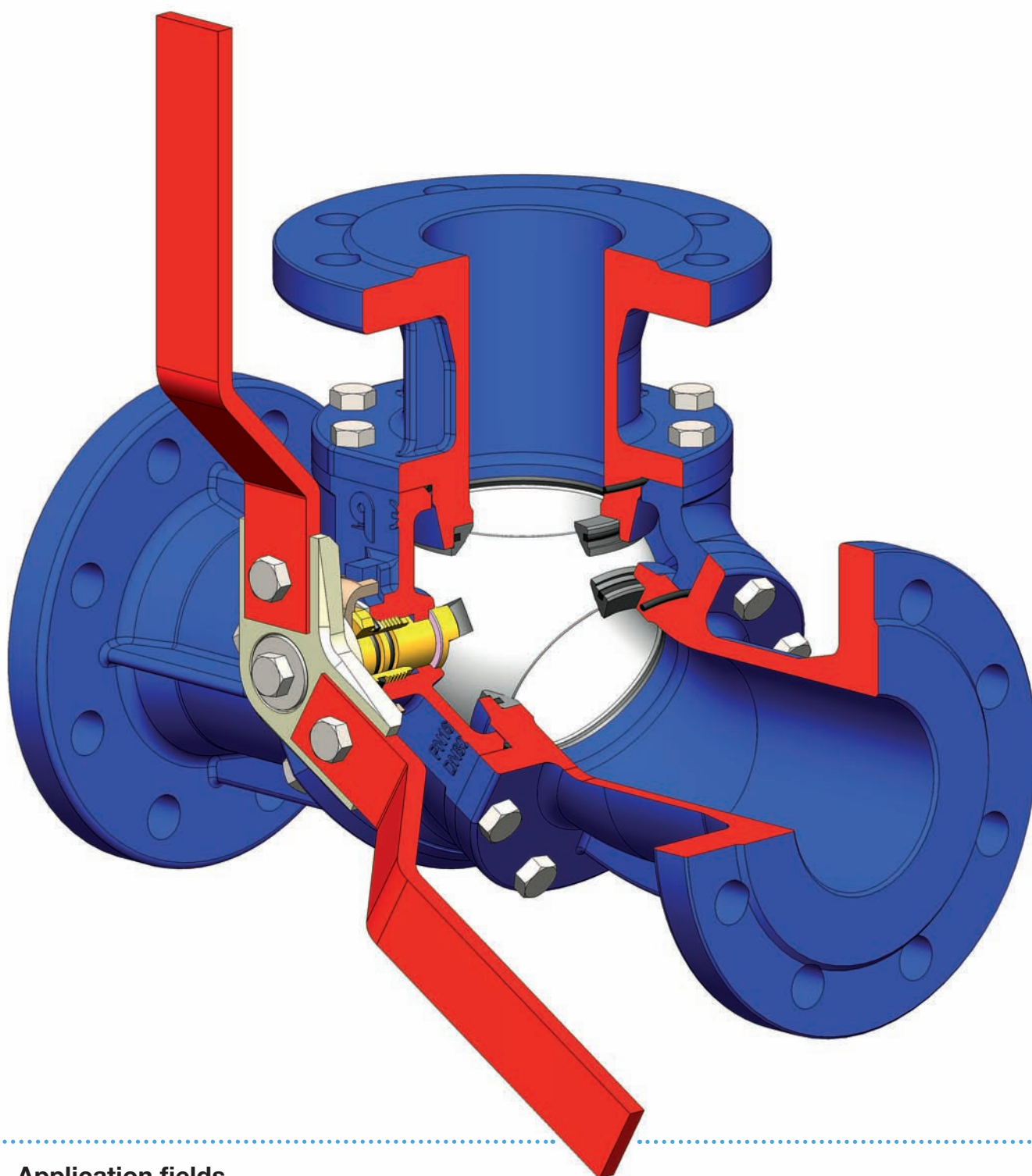

**Application fields**

## Serie 04.1

The valves in the 04.1 series are three-way, diverter ball valves made of cast iron, with floating ball, manufactured in accordance with the most severe product standards and the quality management of ISO 9001.

They are available in the following versions:

**T4** > with "T"-shape flanges (90°)    **Y4** > with "Y"-shape flanges (120°)

In all positions, the three way valve guarantees the connection to the atmosphere or to a security pipe, with progressive distribution (TRANSFLOW); for this reason, while one line is closed, the other two lines will be fully open, and as a result, any incorrect alignment resulting in the choking of the bore of one of the lines will lead to the bore of the others being increased. Suitable for heating and conditioning (HVAC), district heating, distribution and treatment of water, industrial applications, agricultural applications, for compressed air processing, oils and hydrocarbons.

*(Please ensure the choice of the corresponding item)*

**YES:** for installation in line and end of line, for services with frequent actuation, suitable for installing a wide range of actuators.

**NO:** for steam, for choking and regulation of the flow.

1. Inside and outside epoxy coating, high temperature resistant.  
Environmentally-friendly, water-based paint.
2. Ball in chrome-plated brass or stainless steel full bore; the smooth, rounded connections between passages at 120° ensure reduced turbulences and low head loss.
3. The double lever at 120° indicates the flow direction.
4. A double O-ring on the stem and the metallic bushing provides a dynamic seal, even in severe working conditions.
5. Blow-out proof stem.
6. Seat of ball in reinforced PTFE, as temperature changes, the operation torque remains constant.
7. The RO-STOP device allows selection of flow direction also on the valve already installed.
8. Non-standard face-to-face dimension.

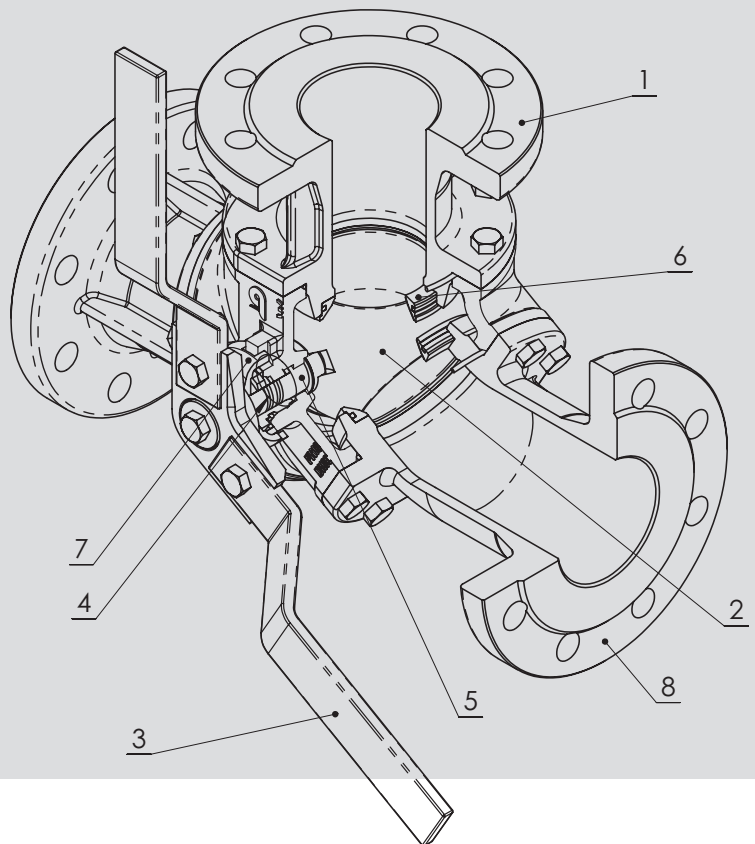

### Accessories

- ➔ Lever with extension for thermal insulation
- ➔ Kit ISO 5211 flange for installation of actuators

*Refer to specifications on page 40*

### Actuators

- ➔ Double acting and single acting pneumatic actuators
- ➔ Electric actuators

**CE** In conformity with directive 97/23/CE PED

### Construction and testing norms (correspondences):

Flanges: EN 1092  
Design: EN 1983, EN13445  
Testing: 100% testing in accordance with EN 12266 cat. A  
(ISO 5208 cat. A)

# Three-way flanged cast iron ball valve

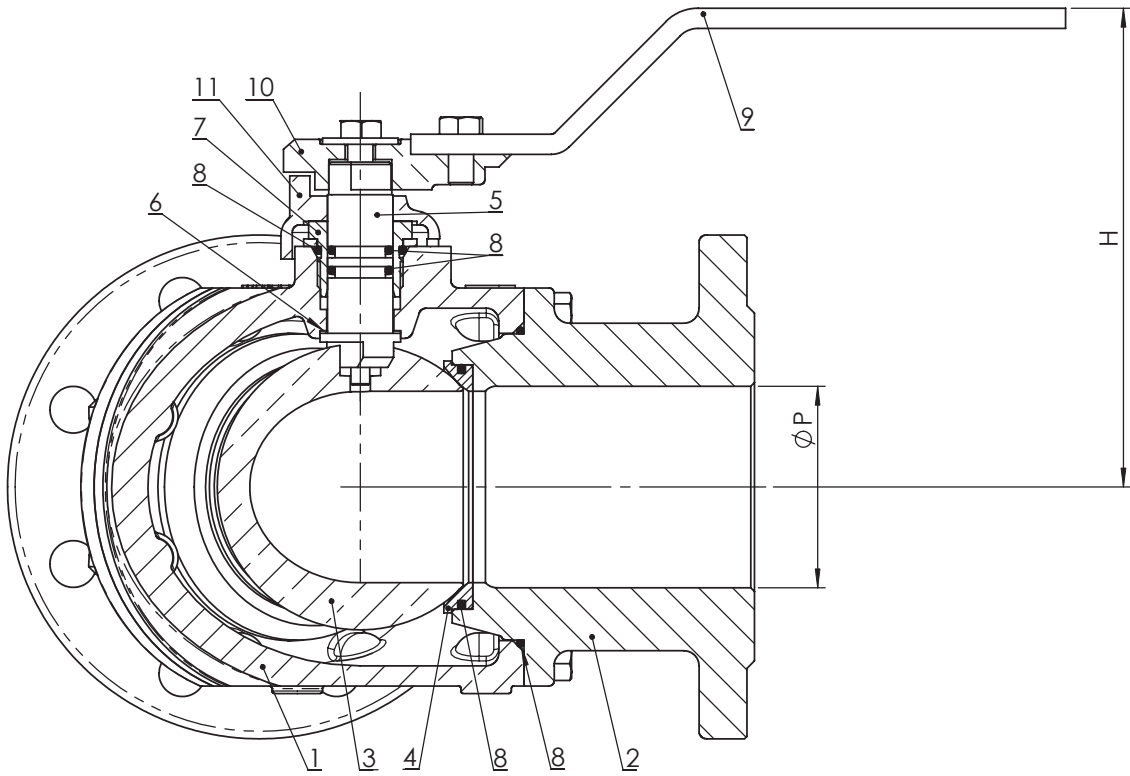

T4.1

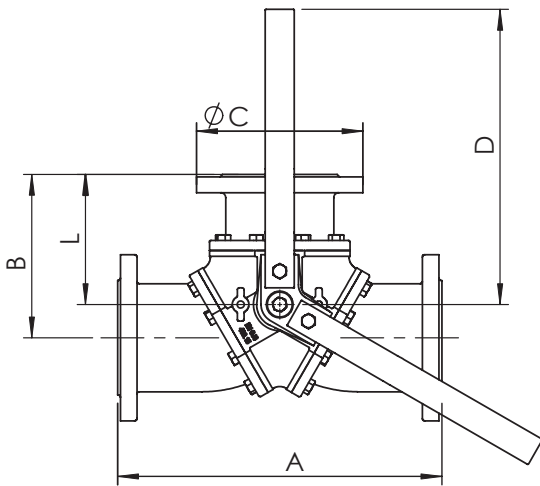

Y4.1

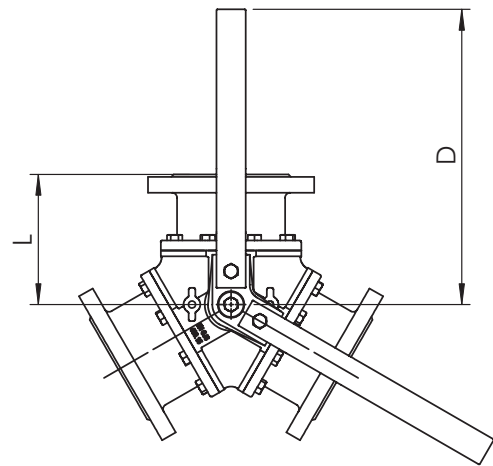

## Materials

	Component	Material
1	Body	EN GJS 400-15
2	Flange	EN GJL 250
3	Ball	Brass CuZn40Pb2 chrome plated / AISI 304
4	Ball seat	Reinforced PTFE
5	Stem	Brass CuZn40Pb2 / AISI 304
6	Sliding washer	PTFE
7	Ring	Brass CuZn40Pb2 / AISI 304
8	O-ring	NBR / FKM (Viton®)
9	Lever	Carbon steel, epoxy coated
10	Lever hub	Brass CuZn40Pb2 galvanized
11	Lever stop RO-STOP	Brass CuZn40Pb2 galvanized
12	Bolts	Galvanized carbon steel

## Dimensions (mm)

DN		50	65	80	100	125	150
P		50	63	76	95	120	145
A	Not standardized	320	350	390	430	490	570
B		160	175	195	215	245	285
C	EN 1092/2 PN16	195	185	200	220	250	285
D		260	350	350	350	475	475
L		130	140	155	165	185	212
H		167	173	187	198	242	261

## Weight (kg)

kg (T)		20	26	34,5	44	70	104
kg (Y)		19	24,5	32,5	40	66	98

## Operating torque (Nm)

Nm		20	40	70	100	180	250
----	--	----	----	----	-----	-----	-----

N.B.: In order to choose the right actuator, we recommend multiplying the operating torque figure by a safety coefficient,  $K=1.5$

## RO-STOP

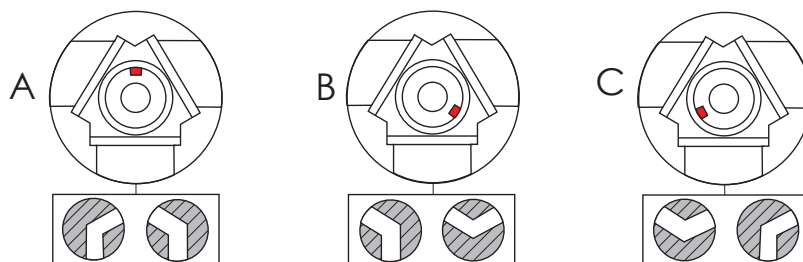
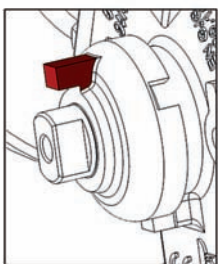

The RO-STOP device ensures extremely easy handling.

■ The red square in the drawing indicates the position of the lever stop of the RO-STOP device.

It indicates the allowed connection between the passage ways in that position, as shown in pictures A, B and C.

N.B. When ordering, specify the required position of the connection (position A, B or C).

# Three-way flanged cast iron ball valve

## Maximum pressure

Fluids *	Mounting	
	BETWEEN FLANGES	END OF LINE
Hazardous gases G1	NO	NO
Hazardous liquids L1	16 bar	10 bar
All remaining fluids G2, L2	16 bar	10 bar

\*: Hazardous gas, liquids (explosive, inflammable, toxic) in accordance with 97/23/CE PED and 67/548/EEC

## Temperature

Temperature	min °C	Max°C			
		continuous		peak	
		L1	G2,L2	L1	G2,L2
NBR	-10	100	100	-	110
FKM (Viton®)	-10	100	150	-	170

NB: the maximum working pressure decreases while the temperature increases; please refer to "pressure/temperature" chart  
G1, L1, G2, L2: see chart to side

## Pressure/temperature chart

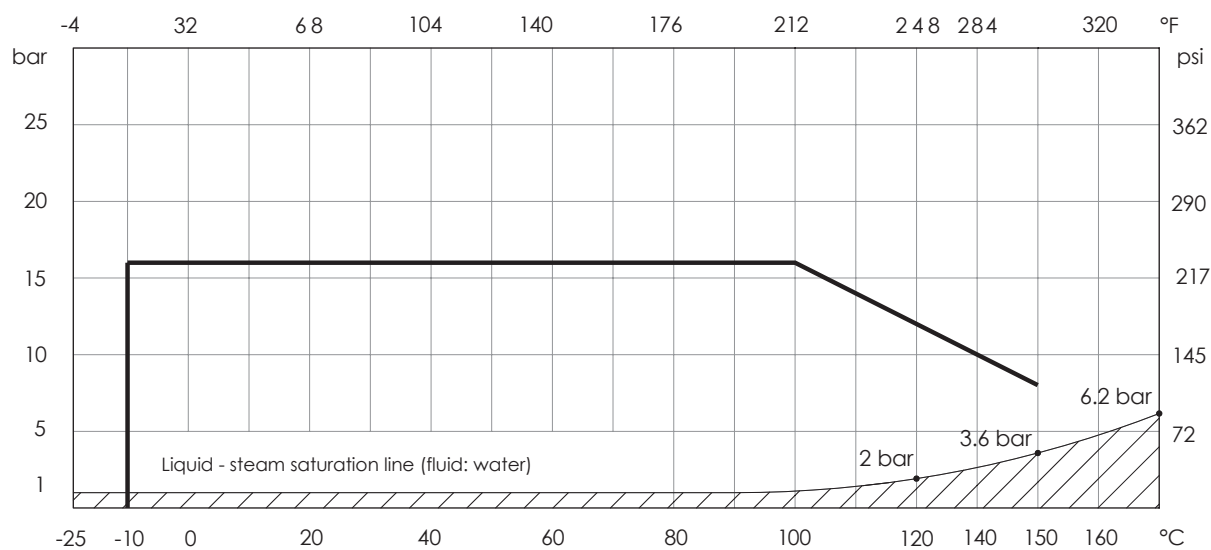

**RANGE NOT SUITABLE FOR STEAM.** DO NOT use when temperature and pressure are below the liquid-steam saturation line ( hatched area )

## Head loss Fluid: water (1m H2O = 0,098bar)

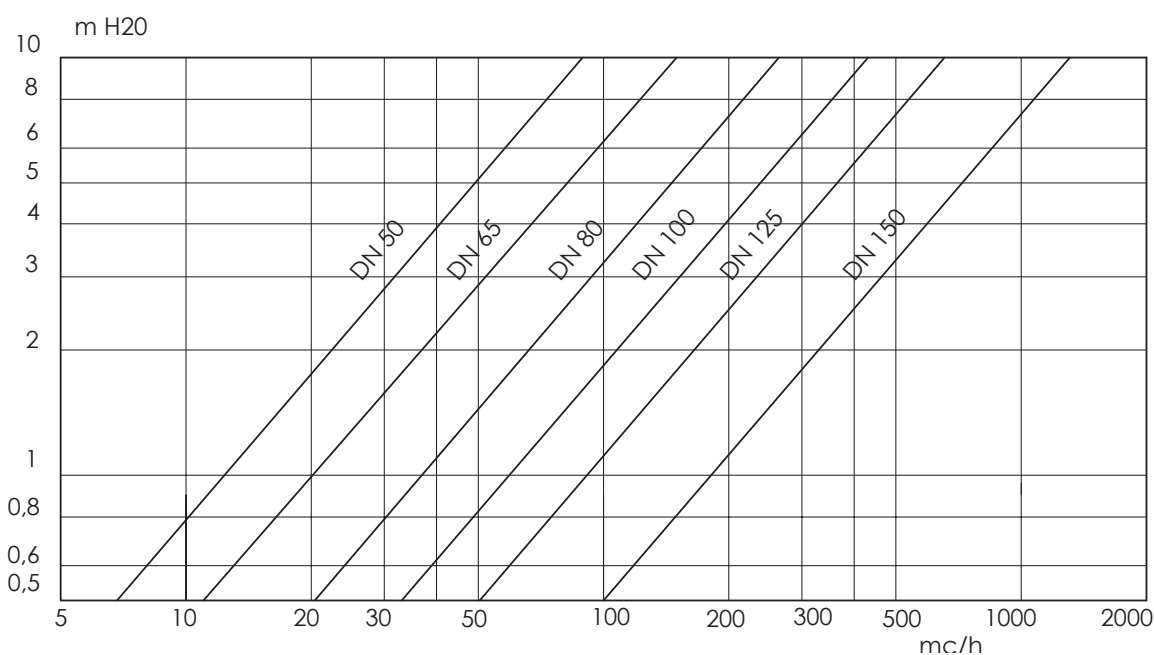

## Kv - DN chart

DN	50	65	80	100	125	150
Kv	90	150	282	420	720	1320

## Versions

### NBR O-ring



T4.1



Y4.1



#### T4.100 - Y4.100

Body: EN GJS 400-15  
 Ball: Brass CuZn40Pb2  
 Stem: Brass CuZn40Pb2  
 O-ring: NBR  
 Temp: -10 +100°C

#### T4.111 - Y4.111

Body: EN GJS 400-15  
 Ball: AISI 304  
 Stem: AISI 304  
 O-ring: NBR  
 Temp: -10 +100°C

Coating: RAL 5002 colour

Shut-off valves

### FKM O-ring



T4.1



Y4.1



#### T4.100 - Y4.100

Body: EN GJS 400-15  
 Ball: Brass CuZn40Pb2  
 Stem: Brass CuZn40Pb2  
 O-ring: FKM  
 Temp: -10 +150°C

#### T4.111 - Y4.111

Body: EN GJS 400-15  
 Ball: AISI 304  
 Stem: AISI 304  
 O-ring: FKM  
 Temp: -10 +150°C

Coating: RAL 5002 colour

\* Most suitable for district heating → for water up to 150 °C

# Three-way flanged cast iron ball valve

## Accessories

### Lever with extension for thermal insulation

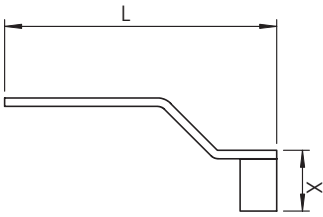

DN	50	65-80-100	125-150
X	50	50	50
L	260	350	475

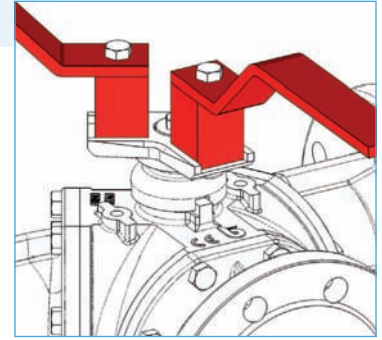

### Kit ISO 5211 flange for mounting of actuators

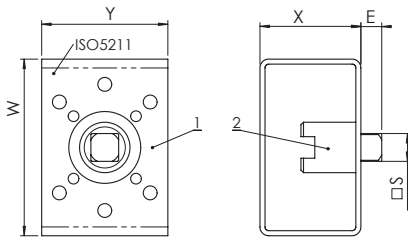

DN	50 - 65	80-100	125-150
ISO 5211	F07/F10	F07/F10	F12
SxE	17x16	22 x 21	27x26
W	120	140	160
X	60	80	80
Y	95	100	120

- 1) Bracket
- 2) Joint

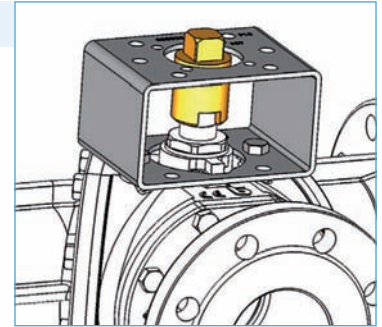



## Instructions and Recommendations

The information provided here is delivered with each product, and contains "Instructions for use and maintenance"; it is also available on our website: [www.brandoni.it](http://www.brandoni.it) (download section)

### STORING

- Keep in a dry and closed place.
- While stored, the valve must be fully open to avoid damages to the seats.

### MAINTENANCE

- It is recommended that the rubber O-rings be replaced at least every 24 months, and the PTFE seats, at least every 48 months. The period of replacement depends on the use of the valve.
- Clean the surface of the valve periodically, in order to prevent accumulation of dust.

### RECOMMENDATIONS

Before carrying out maintenance or dismantling the valve, be sure that the pipes, valves and liquids have cooled down, that the pressure has decreased and that the lines and pipes have been drained in case of toxic, corrosive, inflammable and caustic liquids.

Temperatures above 50°C and below 0°C might cause damage to people.

### WARNING ABOUT PROPER USE

The three-way ball valve Series 04 is a TRANS-FLOW valve with floating ball; when moving, all three ports of the valve are temporarily open, and as a result, the flow switches from one port to the other progressively. These features mean that, for proper use, the pressure acts against the seat of the closed port, and NOT FROM THE CLOSED PORT SIDE (see 1). In this case, leakage and ball seat damage may occur.

FIG. 1

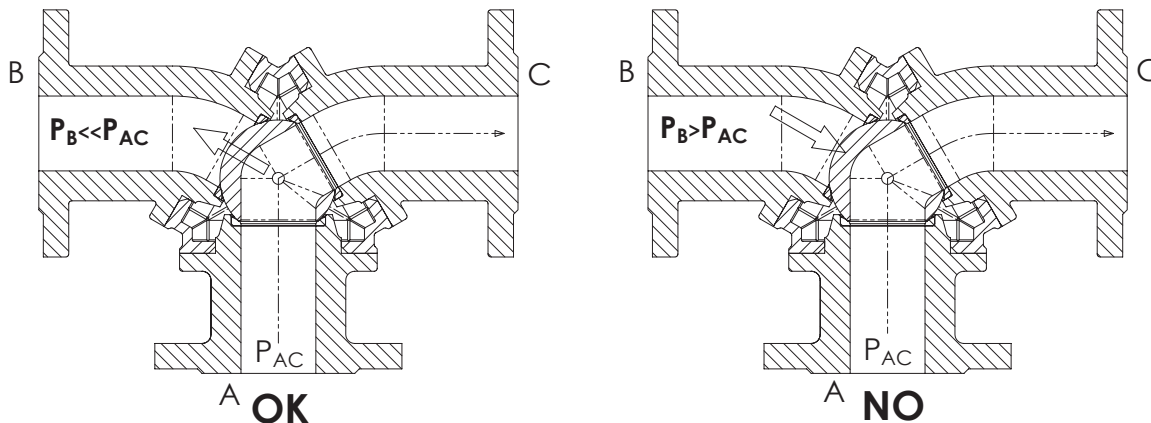

### INSTALLATION

- Handle with care.
- The valve must be installed in the ON or OFF position.
- Place the valve between the flanges of the pipe and install the seal between the pipe and valve flanges. Check the correct position of the seals.
- Do not use bolts of the counter flanges to bring the piping close to the valve. The bolts must be cross tightened.
- Do not weld the flanges to the piping after installing the valve.
- Water hammers might cause damage and ruptures. Inclinations, torsions and misalignments of the piping may subject the installed valve to excessive stresses. It is recommended that elastic joints be used in order to reduce such effects as much as possible.
- While heating from room temperature to the high operating temperature, the liquid located between the body and ball (valve open), or located in the bore of the ball (valve closed) tends to expand and may damage the ball and the seats; it is recommended that the valve be opened and closed at intermediate temperatures during the heating process (for example at 40°C /60°C/...) Special valves with drain plugs are available for this application. At sub-zero temperatures, the liquid between the body and ball may freeze, causing irreparable damage. If the valve is exposed to such conditions, insulation of the valve is recommended.
- It is recommended that the ball valves be operated periodically, to prevent the build-up of materials on the ball and on the seats.