

# D-020-SB PN 16



## Underground Air Valve System for Wastewater

### Description

The D-020 SB is a complete product package that combines the reliable and efficient properties of the A.R.I. D-020 combination wastewater air valve with the added feature of a sub-surface valve that can be buried below ground. A specially designed gear box operated horizontal sliding disc valve - situated at the base of the D-020 SB assembly - allows for the air valve disconnection and maintenance from ground level.

This shut-off valve is equipped with a safety mechanism enabling disconnection and removal of the D-020 air valve from its subsurface housing, even when the system is under pressure. Since service and maintenance operations of the unit are performed entirely from the surface, there is no need for safety considerations associated with confined space entry.

The D-020 Combination Air Valve combines an air & vacuum orifice and an air release orifice in a single body. The valve is specially designed to operate with liquids carrying solid particles such as wastewater and effluents. The combination air valve discharges air (gases) during the filling or charging of the system, admits air into the system while it is being emptied of liquid and releases accumulated air (gases) from the system while it is under pressure and operating. The valve's unique design enables the separation of the liquid from the sealing mechanism and assures optimum working conditions.

### Applications

- Pump stations for sewage, wastewater & water treatment plants.
- Wastewater, effluent water and sea water supply lines.

### Operation

The air & vacuum component discharges air at high flow rates during the filling of the system and admits air into the system at high flow rates during its drainage and at water column separation. High velocity air will not blow the float shut. Water will lift the float which seals the valve.

At any time during system operation, should internal pressure of the system fall below atmospheric pressure, air will enter the system. The smooth discharge of air reduces pressure surges and other destructive phenomena.

The intake of air in response to negative pressure protects the system from destructive vacuum conditions and prevents damage caused by water column separation. Air entry is essential to efficiently drain the system.

The air release component releases entrapped air in pressurized systems.

**Without air valves, pockets of accumulated and entrained air may cause the following hydraulic disturbances:**

- Restriction of effective flow due to a throttling effect as would a partially closed valve. In extreme cases this will cause complete flow stoppage.
- Obstruction of efficient hydraulic transmission due to air flow disturbances.
- Accelerate cavitation damages.
- Pressure transients and surges.
- Corrosion in pipes, fittings and accessories.
- Danger of high-energy bursts of compressed air.
- Inaccuracies in flow metering.

**As the system starts to fill, the combination wastewater valve functions according to the following stages:**

1. Entrapped air/gas is discharged by the valve.
2. When the liquid level reaches the valve's lower portion, the lower float is lifted, pushing the sealing mechanism to its sealing position.
3. The entrapped air is confined in a pocket between the liquid and the sealing mechanism. The air pressure is equal to the system pressure.
4. Increases in system pressure compress the trapped air in the upper section of the conical chamber. The conical shape assures the height of the air gap. This enables separation of the liquid from the sealing mechanism.
5. Entrapped air (gas), accumulating at peaks and along the system, rises to the top of the valve, and displaces the liquid in the valve's body.
6. When the liquid level is lowered to a point where the float is no longer buoyant, the float drops, unsealing the rolling seal. The air release orifice opens and allows part of the air that accumulated in the upper portion of the valve to be released to the atmosphere.
7. Liquid enters the valve. The float rises, pushing the rolling seal to its sealing position. The remaining air gap prevents the wastewater from fouling the mechanism.

**When internal pressure falls below atmospheric pressure (negative pressure):**

1. The floats will immediately drop down, opening the air & vacuum and air release orifices.
2. Air will enter the system.

## Main Features

### D-020 SB Underground Air Valve System for Wastewater:

- The D-020 SB incorporates an integral, flat, gear box operated horizontal sliding disc valve with a 3" full bore passage.
- The shut-off valve is operated from the surface.
- Easy and efficient back flushing can be achieved while the air valve is in its sub-surface housing.
- All connections utilize quick connectors to facilitate easy usage during:
  1. Handling (quick connector from adaptor to shut-off valve)
  2. Maintenance operations (quick connectors on both the inlet & outlet flushing positions).
- Safety elements: Disengaging the air valve is safeguarded: unless the shut-off valve is in the "closed" position and the internal pressure is released, it is not possible to extract the air valve.
- Pipe connections: 3" threaded (BSP/NPT) or flanged, in accordance with all standards.
- All parts are corrosion resistant: Metal parts made of Stainless Steel, Ductile Iron or steel, Composite material parts made of Nylon, PA, and PVC
- Drainage system: a special one-way valve that drains the water from the valve box and does not admit water.

### D-020 Combination Wastewater Air Valve:

- Working pressure range: 0.2 - 16 bar.
- Testing pressure: 25 bar.
- Maximum working temperature: 60° C.
- Maximum intermittent temperature: 90° C.
- A combination air valve for wastewater, with a large air & vacuum orifice and a small air release orifice integrated into one body.
- The unique design of the valve prevents contact between the wastewater and the sealing mechanism by creating an air gap at the top of the valve. These features are achieved by:
  1. **The conical body shape:** designed to maintain the maximum distance between the liquid and the sealing mechanism and still obtain minimum body length.
  2. **Spring-loaded joint between the stem and the upper float:** vibrations of the lower float will not unseal the air release component. Release of air will occur only after enough air accumulates.
  3. **The Rolling Seal Mechanism:** less sensitive to pressure differentials than a direct float seal. It accomplishes this by having a comparably large orifice for a wide pressure range (up to 16 bar).
  4. **Funnel-shaped lower body:** designed to ensure that residue wastewater matter will fall back into the system and be carried away by the main pipe.
- Dynamic design allows for high velocity air discharge while preventing premature closure.

- All inner metal parts made of stainless steel.

## Advantages and Benefits

- Relatively lightweight and convenient to install.

- Sub-surface installation.
- Low installation costs:
  1. No need for expensive, large excavation.
  2. No need for expensive, human-accessible manholes.
- Low Maintenance costs:
  1. No need for specialized tools or safety equipment.
  2. One person for operation and maintenance.
  3. Clean and environmentally friendly.
  4. Complete service and maintenance system, including an integral disassembly mechanism to ensure easy back flushing and servicing, while reducing the need for spare changeable valves.
- Safe in operation:
  1. Greatly reduces the danger of contact with local fauna – snakes and scorpions, etc!
  2. Entirely operated and maintained from ground level.
- Reliable and efficient operation:
  1. Dynamic design allows high velocity air discharge while preventing premature closure.
  2. A.R.I. patented Rolling Seal mechanism.
  3. Since the valve is a sub-surface (underground), it is more resistant to frost conditions.

## Valve Selection

- Two different installation lengths:
  1. 800mm tube; complete system length: 934 mm.
  2. 1000mm tube; complete system length: 1134 mm.
- Air valve body: Stainless Steel SAE 316 or Steel DIN St.37.
- Valve body coating: fusion bonded epoxy coating according to the standard DIN 30677-2.
- Other coatings are available upon request.
- Cover and top air valve body: Reinforced Nylon or Stainless Steel SAE 316.
- Additional Accessories:
  1. With a One-way, Out-only attachment, allows for air discharge only, prevents air intake.
  2. With a Vacuum Breaker, In-only attachment, allows for air intake only, prevents air discharge.
  3. With a Non-Slam discharge-throttling attachment, allows for free air intake, throttles air discharge.

**Upon ordering, please specify:** model, size, working pressure, threads standard and type of liquid.

## UNDERGROUND AIR VALVE SYSTEM PARTS LIST AND SPECIFICATION

No	Part	Material
1.	Discharge Outlet	Polypropylene
2.	Valve Box Cover	Polyethylene
3.	Drainage Outlet	Polyethylene
4.	Lifting Assembly	Stainless Steel SAE 304
5.	Ball Valve 1 1/2"	Stainless Steel SAE 304
6.	Pressure Relief Cock	Stainless Steel SAE 316
7.	Operating Rod	Stainless Steel SAE 304
8.	D-020 Air Valve	see below
9.	Sliding Disc Valve w/ Gear Box	DI+STST+E.P.D.M.
10.	Adaptor - Quick Connector 3"	Stainless Steel SAE 316
11.	Safety Handle	Stainless Steel SAE 316
12.	"T" Key	Stainless Steel SAE 304
13.	Valve Box	Polyethylene
14.	Drainage Valve & Connection	Polypropylene + Acetal
15.	Flange 3"	Reinforced Nylon

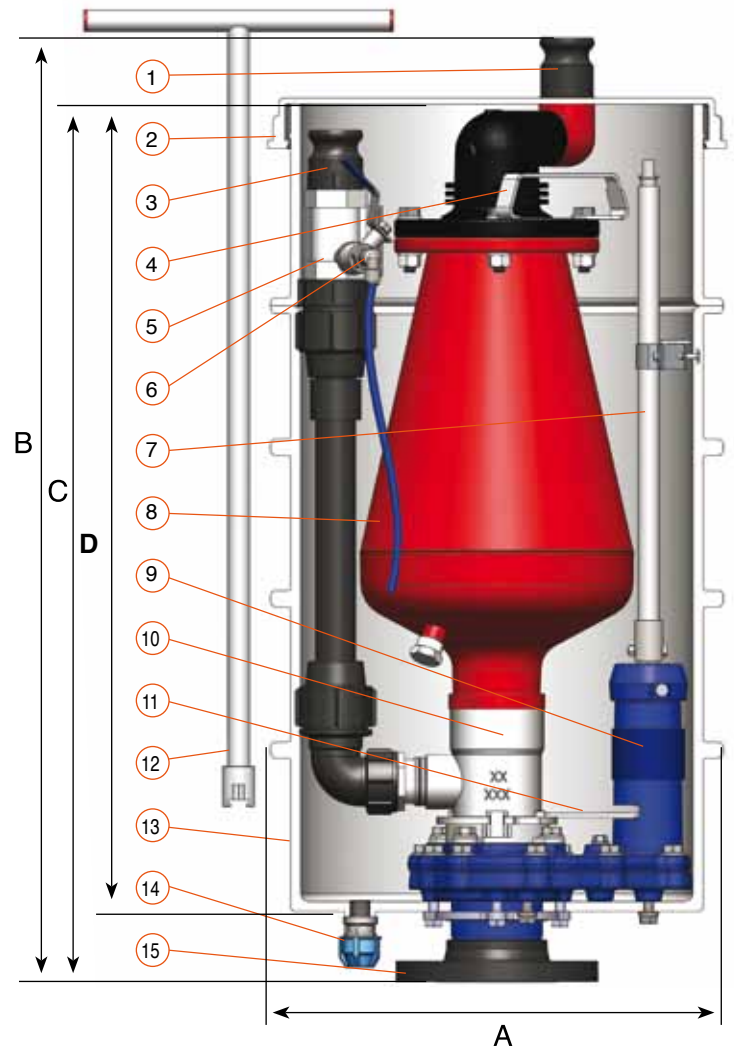

## D-020 PARTS LIST AND SPECIFICATION

No. Part	Material	
1.	Discharge Outlet	Polypropylene
2.	Rolling Seal Assembly	Reinforced Nylon+E.P.D.M+St.St.
3.	Float	Foamed Polypropylene
4.	Clamping Stem	Reinforced Nylon
5.	Body	Reinforced Nylon /Stainless Steel SAE 316
6.	Bolt, Nut & Washer	Stainless Steel SAE 316
7.	Cover	Reinforced Nylon /Stainless Steel SAE 316
8.	O-Ring	BUNA-N
9.	Crown Nut	Stainless Steel SAE 304
10.	Stopper	Polypropylene
11.	O-Ring	BUNA-N
12.	Spring	Stainless Steel SAE 316
13.	Washer	Stainless Steel SAE 316
14.	Stem	Stainless Steel SAE 316
15.	Float	Polycarbonate /Stainless Steel SAE 316
16.	Plug	Stainless Steel SAE 304
17.	Body	Steel DIN St. 37 / Stainless Steel SAE 316

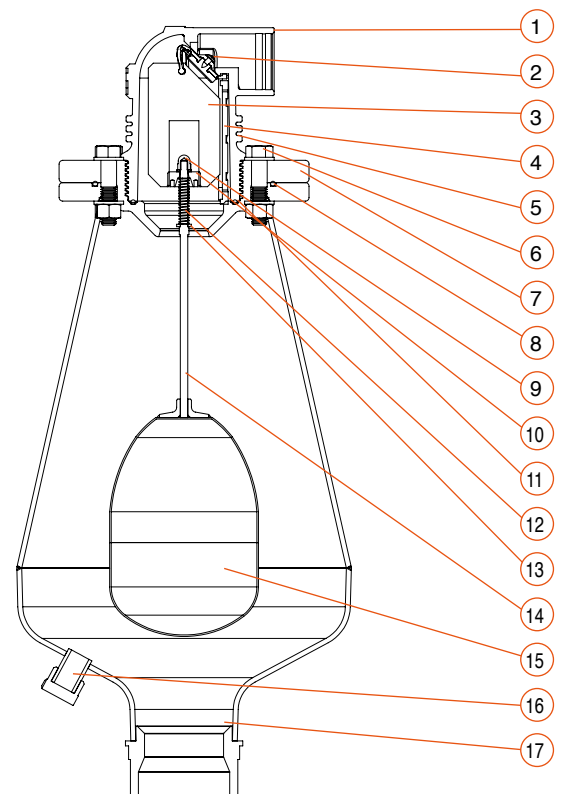

## AIR & VACUUM FLOW RATE

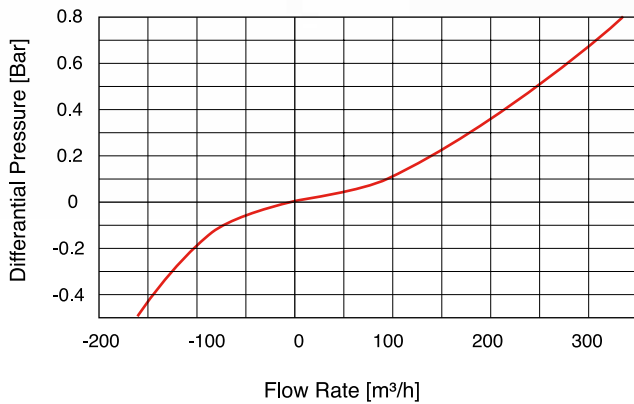

## Sample Installation Scheme

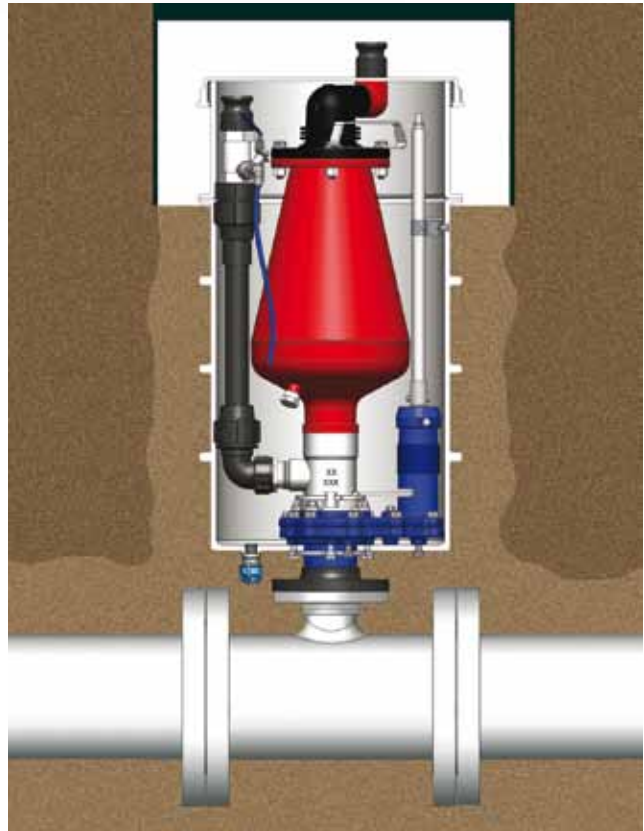

**Important Information:** Prior to site preparation and installation, please refer to the D-020 SB Installation and Maintenance Manual for all the relevant instructions and information. The manual can be obtained by contacting the A.R.I. marketing dept., from your local A.R.I. distributor or downloading the file from our website.

## AUTOMATIC AIR RELEASE FLOW RATE

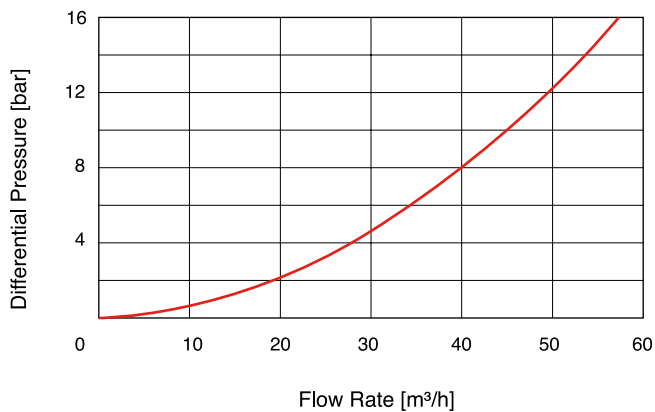

## DIMENSIONS AND WEIGHTS

Model	Dimensions				Weight Kg.	Orifice Area mm <sup>2</sup>	
	A	B	C	D		Auto.	A / V
L800	448	934	875	806	46.8	12	804
L1000	448	1134	1075	1006	49.8	12	804



[www.vatech.dk](http://www.vatech.dk)