

## Flangehale PN 10/16 efter DIN EN 545 Serie A.

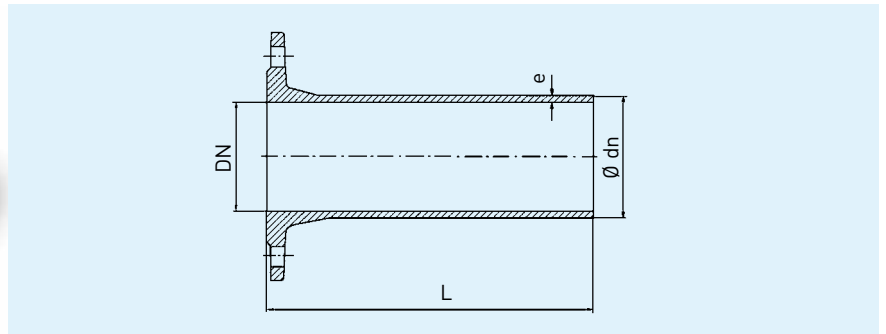

DN	Ø dn	Mål i mm.		kg/stk.
		L	e	
40	56	400	7,0	4,9
50	66	400	7,0	6,1
65	82	400	7,0	7,6
80	98	350	7,0	7,7
100	118	360	7,2	9,7
125	144	370	7,5	12,4
150	170	380	7,8	16,3
200	222	400	8,4	25,3
250	274	420	9,0	35,2
300	326	440	9,6	53,7
350	378	460	10,2	74,0
400	429	480	10,8	74,0
500	532	520	12,0	113,6
600	635	560	13,2	173,1
700	738	600	14,4	183,0
800	842	600	15,6	314,3
900	945	600	16,8	357,0
1000	1048	600	18,0	380,0