

Standard design: spring housing mounted on right when viewed in direction of flow. (Available mounted on left on request)

| DN | a | b | c | l | kg |
|-----|-----|-----|-----|-----|--------|
| 100 | 165 | 325 | 355 | 300 | 42,60 |
| 125 | 185 | 340 | 400 | 350 | 55,60 |
| 150 | 215 | 380 | 460 | 400 | 68,60 |
| 200 | 270 | 460 | 540 | 500 | 131,00 |

Copyright as per DIN 34

Scale: \times

RSK-FTU (DN 100 - DN 200)

STRATE non-return valve with spring-loading and by-pass with stop-cock

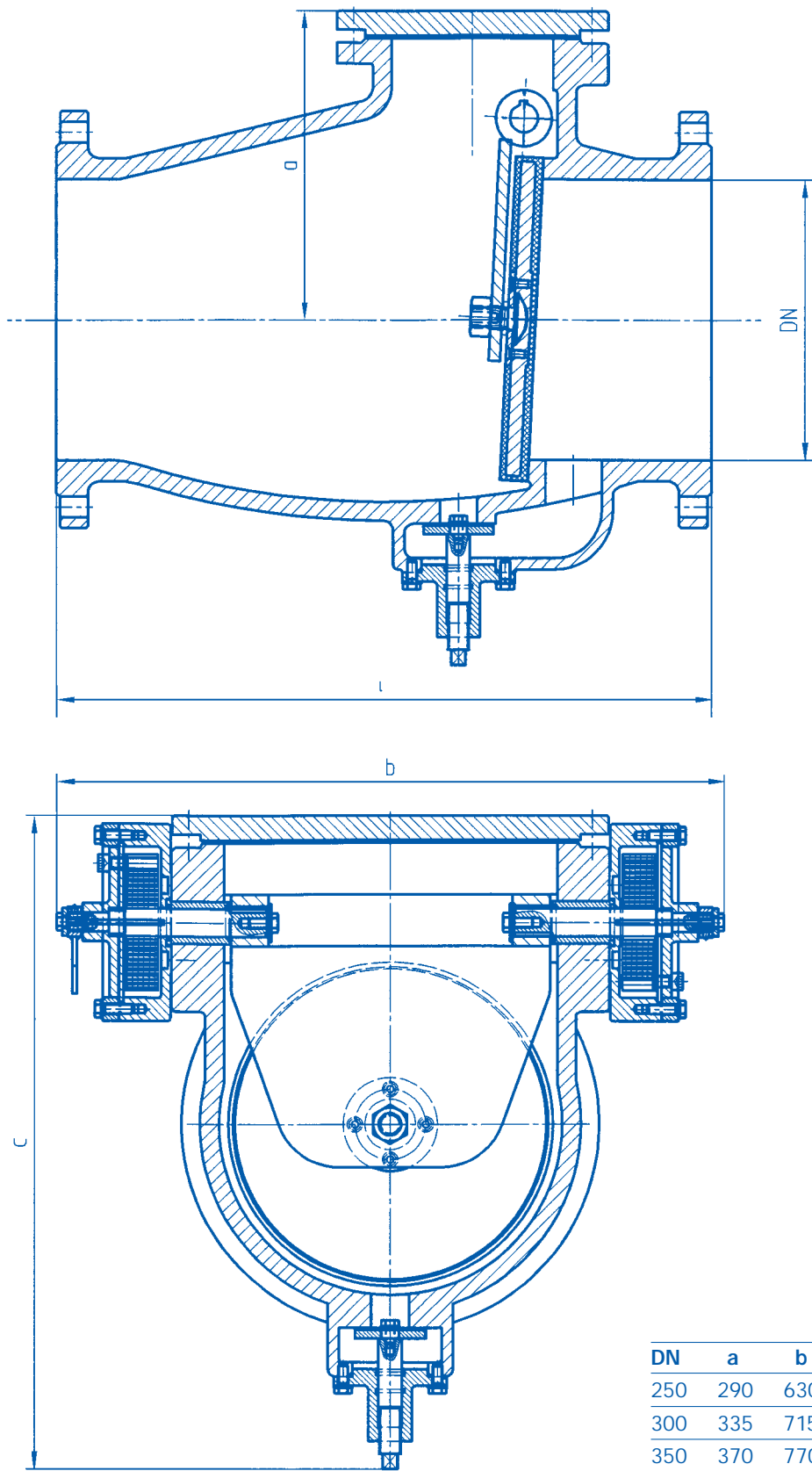

| DN | a | b | c | l | kg |
|-----|-----|-----|-----|-----|--------|
| 250 | 290 | 630 | 630 | 600 | 185,40 |
| 300 | 335 | 715 | 700 | 700 | 280,40 |
| 350 | 370 | 770 | 770 | 800 | 352,40 |

| | |
|-------------------------|---|
| Copyright as per DIN 34 | RSK-FTU (DN 250 - DN 350) STRATE non-return valve with spring-loading and by-pass with stop-cock |
| Scale: 1:1 | |

